

Unique Cardan (Propeller) Shafts

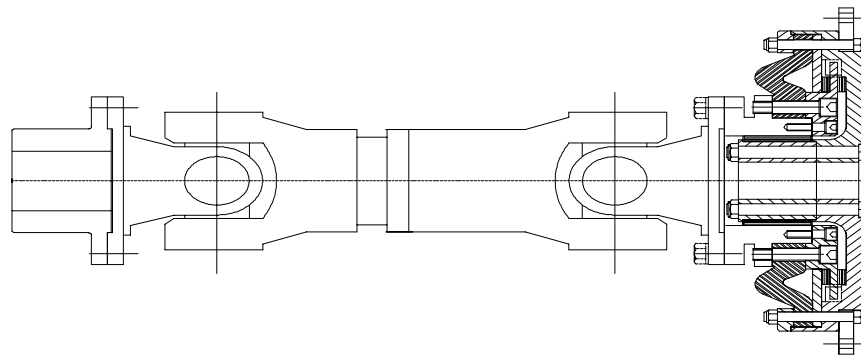
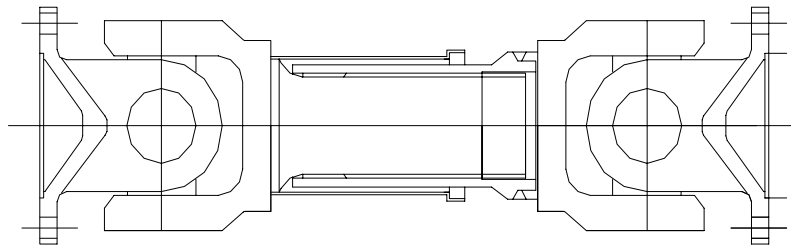

Unique Cardan shaft along with Unique Double Diaphragm Coupling
Specially suitable for Diesel Driven VT Pumps

- ***Unique Cardan shaft are suitable for connecting widely apart machines.
- *** These can take large misalignments.
- *** Specially suitable for Steel Rolling Mills , Tube Mills , Paper Mills
Locomotives , Pump drive, Line shaft , Testing machines, Crane travel
Bogey Drive , Vibrating Screen , Tea Machines etc
- *** Can be used in horizontal , vertical , angular layout
- *** Available for torque ratings upto 100000 Nm
- *** Can be supplied with companion hubs & special end attachments.

Unique Transmission (India) Pvt Ltd.

Selection of Unique Cardan Shafts

Step 1 - Selection considering Bearing Life.

Graphs - data sheets give rating based on Service factor = 1.0 & Joint angle not exceeding 3 degrees, smooth load & bearing life 5000 Hours. For a given application following Service factors should be considered.

Service Factor $K = K1 * K2 * K3$

Multiply transmitted HP by Service Factor $K = K1 * K2 * K3$ to arrive at design HP & select shaft size using HP Rating vs Speed Table given in this catalogue.

K1 depends on type of primemover, Values are

Type of Primemover	Without torsionally resilient Flexible Coupling K1	With Highly resilient Flexible Coupling K1
Petrol Engine 1-3 cyl	1.5	1.0
Diesel Engine 1-3 Cyl	2.0	1.5
Petrol Engine 4 or more Cyl	1.25	1.0
Diesel Engine 4 or more Cyl	1.50	1.1
Electric Motor	1.00	1.0

K2 depends on life of Bearings

Life in Hours	5000	10000	20000	37000	50000	75000	100000	200000
K2	1.0	1.2	1.6	1.8	2.0	2.25	2.5	3.0

K3 depends on Joint Angle

Joint Angle Degrees	3	4	6	8	10	12	15
K3	1.0	1.1	1.25	1.4	1.5	1.6	1.7

CHECK - There is a safe limit for Joint Angle, B for a given RPM. $N * B$ must not exceed following values. Where N is rpm & A is Joint Angle in degrees. Higher joint angles cause high vibratory torque - causing premature failure/ excessive vibratory torque.

Cardan shaft Series	1140,1310	1410,2872	3120	1510,1600, 1700	1800	1900
N*B max	25000	23000	21000	18000	12000	10000

Thus for Series 1700, if operating speed is 1800 rpm, Max permissible Joint angle is $18000/1800 = 10$ degrees

Cardan shaft Series	116.150	133.150	133.180	144.180	172.225
N*B max	20000	18000	18000	15500	15500

Thus for Series 172.225, if operating speed is 1800 rpm, Max permissible Joint angle is $15500/1800 = 8.6$ degrees

Step 2 - Check for Maximum shock Torque that may occur

Transmitted normal Torque - as calculated from Power transmitted & operating RPM should be multiplied by shock factor K4 to arrive at max Torque.

$Q_{max} = P * 60000 * K4 / (2 * 3.142 * N)$ Nm where P is Power in KW, N is RPM, K4 is shock factor

Type of Driven Machine	K4
Continious Loads (Pumps, Fans, Conveyors)	1.2-1.5



Light Shock Load (Printing m/c , small Paper m/c , textile m/c)	1.5-2.0
Medium Shock load (heavy paper , textile m/c Tube Mill , Pinch Roll)	2.5
Heavy Shock Load (Roller tables , presses, heavy tube mills , crane travel drives)	3.0
Extreme shock loads (Reversing working roller tables , vibrating conveyors)	4.0 to 6.0
Qmax - should be less than Max Torque capacity as stated in catalogue for different models.	

Step 3 - Check For Critical Speed for Lateral Vibration.

It is necessary to check for Critical speed

$$N_c = 167 * D_m / L^2$$

where D_m is Mean Tube dia in mm $= (D_o + D_i) / 2$

D_o is Tube OD in mm . D_i is Tube ID in mm

L is span - Jt centre to Jt Centre in m.

Metre Jt Cr to Jt Cr

Operating speed must not exceed $0.70 * N_c$

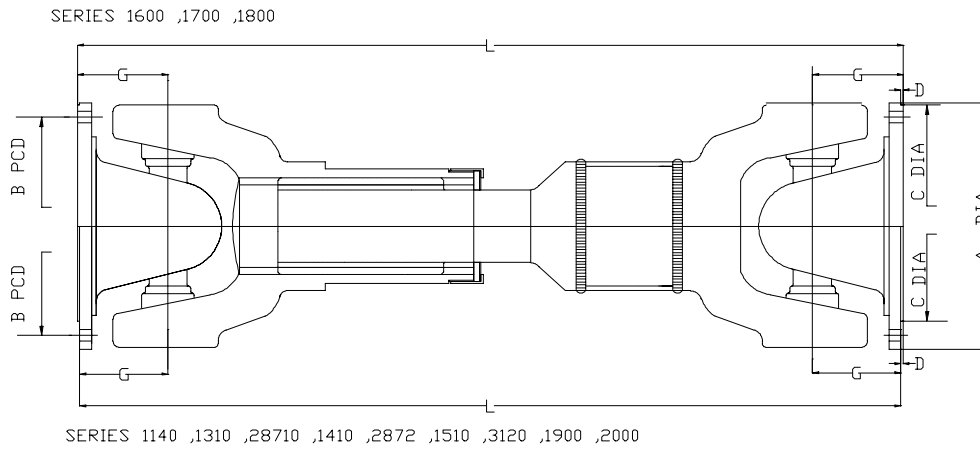
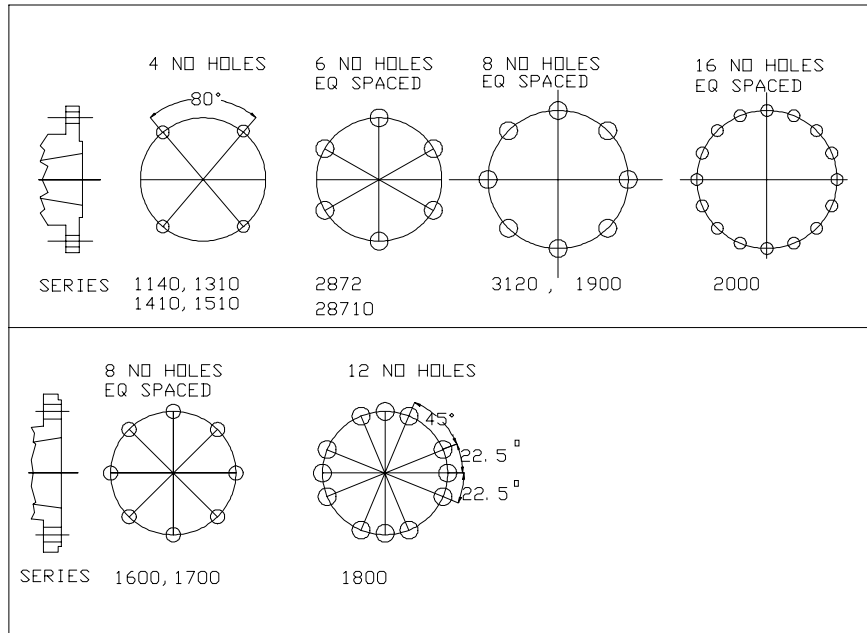

Unique Transmission (India) Pvt Ltd

UNIQUE CARDAN SHAFTS SERIES 1140 TO SERIES 2000
DIMENSIONS

SERIES	Max Torque Short Duration	A FLANGE DIA	BOLTS		MAX JOINT ANGLE	Joint Rotation Dia	C SPIGOT DIA	D SPIGOT HEIGHT	G FL FACE TO JT CENTRE	I FL TH	P TOTAL TELES-COPIC MOVEMENT	BOLT TIGHT. TORQUE
			B PCD	DIA*No								
	Nm	MM	MM	MM	DEGREE		MM	MM	MM	MM	MM	NM
1140	571	87.3	69.8	M 8*4	20	76	56.10	1.6	28.6	5.1	46	20
1140-DIN58**	150	58	47	M 5*4	20	76	30	-1.5		5.1	46	7
1140-DIN65**	250	65	52	M 6*4	20	76	35	-1.7		5.1	46	13
1140-DIN75**	400	75	62	M 6*6	20	76	42	-2.0		5.1	46	13
1310	800	96.8	79.4	3/8"*4	20	97	60.30	1.6	41.3	6.7	46	40
1310-DIN90**	750	90	74.5	M8*4	20	97	47	-2.5	55.0	6.7	46	32
28710	1350	100	84	M8*6	18	97	56.90	2.0	48.0	7.8	45	20
28710-DIN90**	750	90	74.5	M8*4	18	97	47.00	-2.5	70.0	7.8	46	20
28710-DIN100*	1350	100	84	M8*6	18	97	57	-2.5	48.0	7.8	45	32
1410M	2100	*	95.2	7/16"*4	20	123	69.85	1.2	42.9	7.5	57	64
2872	2400	120	101.4	M10*6	20	116	82.50	2.0	54.0	7.8	60	48
2872-DIN90	1350	90	74.5	M8*4	20	116	47	-2.5	70.0	7.8	60	20
2872-DIN100**	1350	100	84	M8*6	20	116	57	-2.5	70.0	7.8	60	32
2872-DIN120**	3000	120	101.5	M10*8	20	116	75	-2.5	54.0	7.8	60	64
1510	3200	146.0	120.6	1/2"*4	20	136	95.20	1.6	63.5	9.1	51	100
1510-DIN120**	3200	120	101.5	M10*8	20	136	75	-2.5	95.0	9.1	51	64
1550	3200	*	120.6	1/2"*4	20	150	95.2	1.6	50.8	9.1	63.5	100
3120	4500	129.0	111.5	M10*8	25	135	82.50	2.0	76.0	8.0	60	48
3120-DIN120**	4500	120	101.5	M10*8	20	135	75	-2.5	76.0	8.0	60	64
3120-DIN150**	4500	150	130	M12*8	20	135	90	-3	76.0	8.0	60	111
1610, 1600	4500	174.6	155.5	3/8"	22	173	168.28	1.6	69.9	9.5	70	40
1600 mod	4500	174.6	155.5	12*16 no	22	173	168.28	1.6	70.0	8.5	70	64
1610-DIN180**	4500	180.0	155.5	M12*8	22	173	110.00	-3.0	75.0	10.0	70	48
1700	6500	203.2	184.1	3/8"	35	200	196.85	1.6	76.2	9.5	75	40
1800	9260	203.2	184.1	7/16"	20	217	196.85	1.6	85.7	11.1	82	64
1900	16700	276.2	247.6	M16	20	268	222.25	2.4	98.4	14.3	82	210
2000	26000	287.3	263.5	1/2"	15	287	196.80	2.4	95.2	14.3	76	100

* 1410/1410M SERIES- RECT. FLANGE , SWING DIA ~ 123 MM

* 1550 SERIES- RECT. FLANGE , SWING DIA ~ 150 MM

NOTES - L LENGTH CAN BE AS REQUIRED

THE DIMENSIONS ARE FOR STANDARD EXECUTIONS AND SUBJECT TO CHANGE WITHOUT NOTICE.

ADDITIONAL INFORMATION ABOUT RATINGS AND GUIDELINES ARE GIVEN SEPERATELY

CARDAN SHAFTS ARE ALSO AVAILABLE IN MANY OTHER STYLES/ASSEMBLIES

SOME ILLUSTRATION FOR ALTERNATIVE ASSEMBLIES ARE GIVEN SEPERATELY.

UNIQUE TRANSMISSION I PVT LTD

Companion Hubs

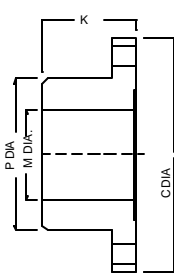

Standard Hub
 Series 1140, 1310,28710
 1410,2872,1510,3120

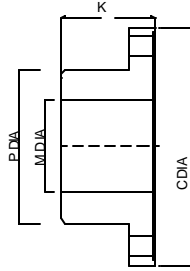

Standard Hub
 Series 1600,1610
 1700,1800

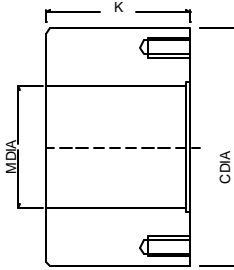

Special Hub
 Series 1140, 1310,28710
 1410,2872,1510,3120

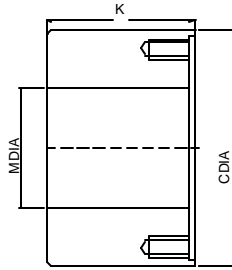

Special Hub
 Series 1600,1700,1800
 1610

Standard Hubs				
Series	C mm	M Max Bore mm	K mm	P mm
1140	87	32	45	57
1310	97	42	51	62
28710	100	48	50	69
1410	116	48	51	73
2872	120	55	55	80
1510	146	62	76	95
3120	130	65	75	90
1600,1610	175	80	89	120
1700	203	100	100	155
1800	203	100	100	155

Special Hubs			
Series	C mm	M Max Bore mm	K mm
1140	87	55	50
1310	97	60	63
28710	100	70	75
1410	116	70	76
2872	120	80	80
1510	146	95	100
3120	130	85	75
1600,1610	175	114	127
1700	203	140	152
1800	203	140	152



Weight & MR² data for Cardan shaft Series 1140 to 1900				
Cardan shaft Series	Weight 1000 mm Length Kg	MR ² 1000 mm Length KgM ²	Change Weight per 100 mm Kg	Change MR ² per 100 mm Kg.m ²
1140	7.2	0.0046	0.5	0.0005
1310	8.5	0.0067	0.5	0.0005
28710	10.5	0.0108	0.6	0.0005
1410	11.9	0.0134	0.6	0.0007
2872	16.2	0.0196	0.6	0.0007
1510	18.5	0.0331	0.6	0.0012
3120	25.0	0.0400	0.6	0.0012
1600,1610	27.6	0.0707	0.6	0.0012
1700	36.8	0.1277	1.0	0.0020
1800	55.8	0.1935	1.0	0.0020
1900	87.8	0.5630	1.4	0.0045

Weight & MR² data for Companion Hub shaft Series 1140 to 1900				
Series	Standard Hub Each		Special Hub Each	
	Weight Kg	MR ² KgM ²	Weight Kg	MR ² KgM ²
1140	0.9	0.0007	1.5	0.0020
1310	1.0	0.0011	2.3	0.0037
28710	1.0	0.0011	2.2	0.0041
1410	1.2	0.0018	4.0	0.0092
2872	1.8	0.0027	4.0	0.0103
1510	3.6	0.0081	7.7	0.0292
3120	2.3	0.0042	3.9	0.0116
1600,1610	5.5	0.0178	13.5	0.0740
1700	10.0	0.0475	20.3	0.1546
1800	10.0	0.0475	20.3	0.1546
1900	24.0	0.2200	52.9	0.7286

Weight and MR² values of companion Hubs are at max bore capacity

Unique Transmission (India) Pvt Ltd

Unique Cardan Shafts Minimum Lengths

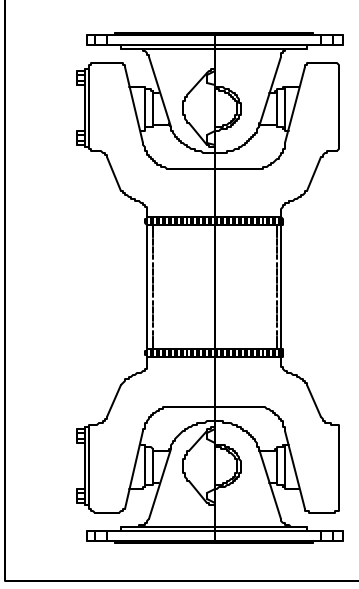

Short Yoke Shaft Assembly

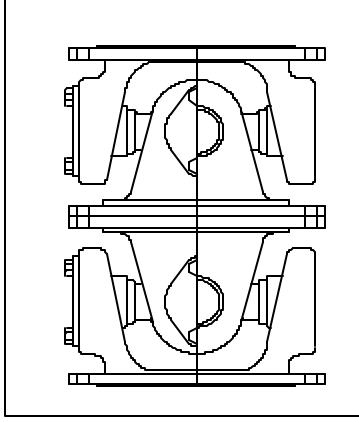

Double Set of 2 Flange Yoke Assy

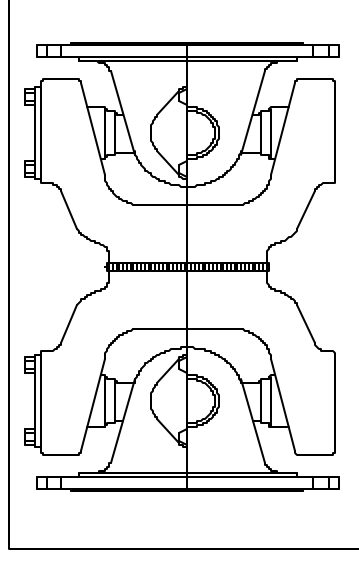

Double Joint

Series	Short Yoke Shaft Assembly		Double Set of 2 Flange Yoke Assy		Double Joint	
	Telescopic Type		Fixed Centre Type , Length mm		Fixed Centre Type , Length mm	
	Normal	Special	Normal	Special	Normal	Special
1140	245	230	121	136	165	136
1310	310	280	168	150	180	150
28710	365	330	192	220	240	220
1410	375	340	174	180	210	180
2872	400	340	220	230	290	230
1510	460	410	254	265	320	265
3120	625	560	304	300	350	300
1600/1610	495	430	280	290	350	290
1700	745	670	305	305	375	305
1800	700	630	343	420	420	420

Nominal Torque ratings for cardan shafts series 1140 to Series 1800 at various speeds
 for smooth loads , Jt angle 3 deg , 5000 hrs life. At SF = 1.0

Series	1140	1310	28710	1410 1410M	2872	1510	3120	1600 1610	1700	1800
Speed	Nominal Torque Rating in NM									
10 rpm	571	800	1350	2100	2400	3200	4000	4500	6500	9260
50 rpm	427	670	1054	1610	1994	2279	2849	3704	5700	7123
100 rpm	356	513	869	1282	1567	1923	2279	2849	4487	5698
250 rpm	259	370	627	969	1225	1425	1652	1994	3276	4416
500 rpm	199	285	541	755	969	1111	1211	1710	2564	3562
750 rpm	180	256	484	665	855	959	1187	1520	2232	3229
1000 rpm	157	228	449	598	784	876	1054	1353	2066	2849
1500 rpm	138	199	394	522	688	760	926	1187	1804	2493
1800 rpm	131	190	376	487	670	712	871	1128	1721	2374
2000 rpm	125	182	360	470	659	694	837	1068	1603	2279
3000 rpm	107	159	335	416	558	605	665	950	1425	1970
4000 rpm	98	142	325	383	499	498	552	837	1264	1781

Continious HP ratings of cardan shafts series 1140 to Series 1800 at various speeds
 For smooth loads , Jt angle 3 deg , 5000 hrs life. At SF = 1.0

Series	1140	1310	28710	1410 1410M	2872	1510	3120	1600 1610	1700	1800
Speed	Nominal HP rating									
10 rpm	0.8	1.1	1.9	2.9	3.3	4	5	6	9	13
50 rpm	3.0	4.7	7.4	11.3	14	16	20	26	40	50
100 rpm	5.0	7.2	12.2	18	22	27	32	40	63	80
250 rpm	9.1	13	22	34	43	50	58	70	115	155
500 rpm	14	20	38	53	68	78	85	120	180	250
750 rpm	19	27	51	70	90	101	125	160	235	340
1000 rpm	22	32	63	84	110	123	148	190	290	400
1500 rpm	29	42	83	110	145	160	195	250	380	525
1800 rpm	33	48	95	123	169	180	220	285	435	600
2000 rpm	35	51	101	132	185	195	235	300	450	640
3000 rpm	45	67	140	175	235	255	280	400	600	830
4000 rpm	55	80	183	215	280	280	310	470	710	1000

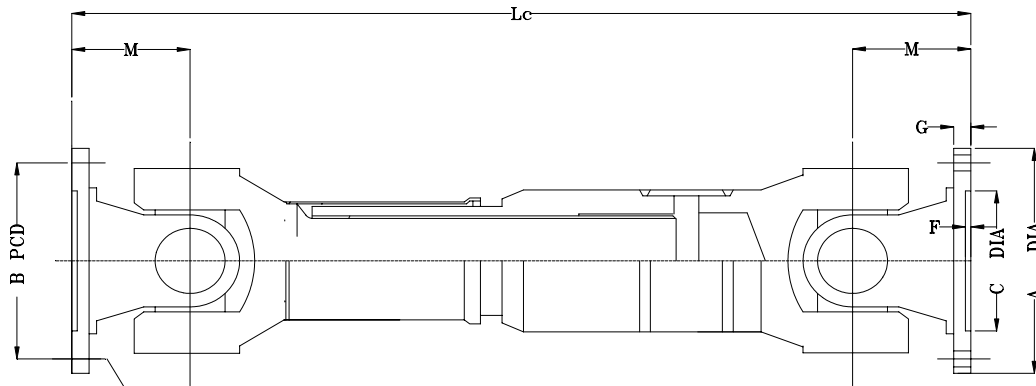

Z = NO OF EQUISPACED HOLES

H = DIA OF HOLES

B = PCD OF HOLES

Cardan Shaft Series	98.120	116.150	133.180	144.180	152.180	185.225
Nominal Torque , Tk KNm	3.0	7.50	11.0	12.6	16.0	33.0
Fatigue Torque Tdw KNm	1.5	2.90	4.4	6.3	7.3	13.0
Bearing Load Cr , KNm	0.9	2.0	3.3	4.2	4.6	8.6
A Dia mm	120	150	180	180	180	225
B , Bolt PCD mm	101.5	130	155.5	155.5	155.5	196
G, Flange Th mm	8	10	12	14	14	16
Z , No of Holes	8	8	8	8	10	8
H , Hole dia mm	10	12	14	14	16	16
C , Dia mm	75	90	110	110	110	140
F Spigot Depth mm	2.5	3.0	3.0	3	3.0	5
M mm	72.5	86	90	100	95	120
Jt Angle max deg	20	35	35	35	25	22
Max Telescopic movement mm	70	110	110	110	110	110
Jt rotation dia mm	116	142	160	170	176	215
Lc Min mm	480	605	690	710	780	680
Tube OD mm	76	89	89	101	114	140
Weight Lc min Kg	13	26	41	47	56	76
Tube Kg/100 mm	0.7	1.0	1.0	1.4	1.8	2.5
Inertia MR ² Lc min KG.CM ²	177	394	900	1040	1356	2700
Tube Inertia MR ² / 100 mm Kg.CM ²	8	19	19	31	50	111

1-Universal Joint Bearing Life $B_{10} = 1.5 \cdot 10^7 (Cr/Q)^{3.33} / (N \cdot B \cdot Kb)$ Hours

Q is tranbsmitted Torque in KNm , N= Operating RPM , B= Operating Joint angle or 2 degrees whichever is higher. , Kb= 1.0 for Elec Motor/Turbine drive . Kb= 1.2 for Diesel Engine

2- Special Shorter Length also offered with reduced telescopic movement on request.

UNIQUE TRANSMISSION (INDIA) PVT LTD
CARDAN SHAFTS

SWC Series cross universal coupling

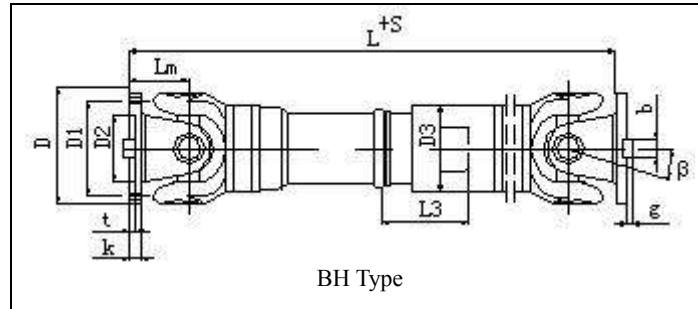
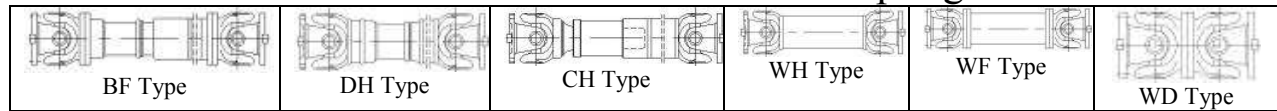

Model	Rotary Diameter D(mm)	Max Torque KN.m	Fatigue Torque Mdw KN.m	Bearing Torque CR KNm	Max Angle β≤	Size								
						D1	D2	D3	Lm	n-d	K	t	b	g
SWC225	225	55	26	11.4	15°	196	135	152	120	8-17	20	5.0	32	9.0
SWC250	250	71	35.5	19.1	15°	218	150	168	140	8-19	25	6.0	40	12.5
SWC285	285	100	50	26.4	15°	245	170	194	160	8-21	27	7.0	40	15.0
SWC315	315	140	70	36.6	15°	280	185	219	180	10-23	32	8.0	40	15.0
SWC350	350	200	100	48.3	15°	310	210	267	194	10-23	35	8.0	50	16.0
SWC390	390	280	140	67.1	15°	345	235	267	215	10-25	40	8.0	70	18.0
SWC440	440	400	200	100	15°	390	255	325	260	16-28	42	10.0	80	20.0
SWC490	490	560	280	130	15°	435	275	325	270	16-31	47	12.0	90	22.5
SWC550	550	800	400	185	15°	492	320	426	305	16-31	50	12.0	100	22.5

Model		225	250	285	315	350	390	440	490	550
BH	Lmin	920	1035	1190	1315	1410	1590	1875	1985	2300
	Weight(kg)	130	180	273	389	601	758	1210	1602	2503
	Ls	140	140	140	140	150	170	190	190	240
BF	Lmin	920	1035	1190	1315	1410	1590	1875	1985	2300
	Weight(kg)	148	210	315	440	662	857	1380	1731	2667
	Ls	140	140	140	140	150	170	190	190	240
DH	Lmin	640	735	880	980	1070	1200			
	Weight(kg)	102	148	240	350	500	655			
	Ls	70	70	80	90	90	90			
CH	Lmin	1500	1615	1875	2000	2115	2245	2510	2620	3085
	Weight(kg)	192	250	375	544	853	1000	1620	1860	3150
	Ls	700	700	800	800	800	800	800	800	1000
WH	Lmin	520	620	720	805	875	955	1155	1205	1355
	Weight(kg)	85	144	215	302	415	566	870	1140	1526
WF	Lmin	610	715	810	915	980	1100	1290	1360	1510
	Weight(kg)	104	150	240	332	452	668	980	1274	1763
WD	Lmin	480	560	640	720	776	860	1040	1080	1220
	Weight(kg)	90	140	201	291	395	554	854	1156	1624

Universal Joint Bearing Life B10 = $1.5 \cdot 10^7 \cdot (CR/Q)^{3.33} / (N \cdot B \cdot K_b)$ Hours

Q = Transmitted Torque in KNm , N is Speed in RPM

B= Operating Joint Angle in Degrees or 2 Whichever is higher

Kb= 1.0 for Motor/Turbine Drives , Kb= 1.2 for Diesel Engine Drives

SWP Series Cardan shaft

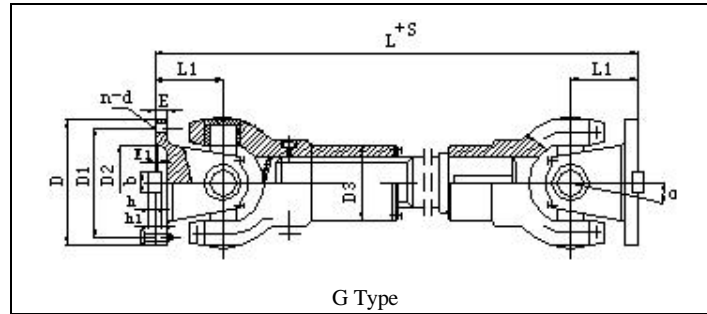
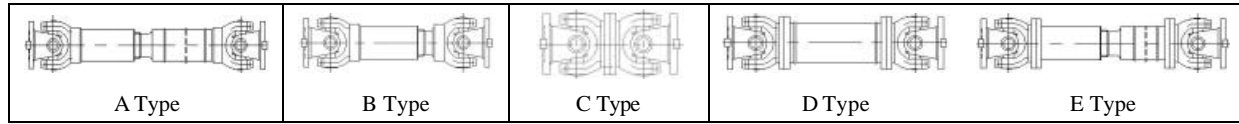

Model	Rotary Diameter D	Nominal Torque Tn Kn.m	Fatigue Torque Tf Kn.m	Axial Angle a =	Size									
					S	D1	D2	D3	E	E1	b*h	h1	L1	n-d
SWP160	160	16	8	10°	50	140	95	114	15	4	20*12	6	85	6-13
SWP180	180	20	10	10°	60	155	105	121	15	4	24*14	7	95	6-15
SWP200	200	31.5	16	10°	70	175	125	127	17	5	28*16	8	110	8-15
SWP225	225	40	20	10°	75	196	135	152	20	5	32*18	12.5	130	8-17
SWP250	250	63	31.5	10°	80	218	150	168	25	5	40*25	15	135	8-19
SWP285	285	90	45	10°	100	245	170	194	27	7	40*30	15	150	8-21
SWP315	315	126	63	10°	110	280	185	219	32	7	40*30	16	170	10-23
SWP350	350	180	90	10°	120	310	210	245	35	8	50*32	18	185	10-23
SWP390	390	250	120	10°	120	345	235	273	40	8	70*36	20	205	10-25
SWP435	435	355	160	10°	150	385	255	299	42	10	80*40	22.5	235	16-28
SWP480	480	450	224	10°	170	425	275	351	47	12	90*45	22.5	265	16-31
SWP550	550	710	355	10°	190	492	320	402	50	12	100*45	27.5	290	16-31
SWP600	600	1000	500	10°	210	544	380	450	55	15	90*55	27.5	330	22-34
SWP640	640	1250	630	10°	230	575	385	480	60	15	100*60	30	350	18-38

Model		160	180	200	225	250	285	315	350	390	435	480	550	600	640
G	Lmin	610	700	780	928	958	1103	1240	1400	1480	1740	1940	2125	2400	2700
	Weight(kg)	60	75	98	135	168	273	367	515	645	1214	1497	2053	2730	3700
	Add Kg/100	3.2	3.8	4.8	6.4	6.4	9.6	12.1	15.8	15.8	24.7	27.1	32.6	50	65
A	Lmin	660	737	823	933	978	1133	1250	1380	1495	1710	1910	2135	2355	2685
	Weight(kg)	57	70	91	119	157	255	345	458	596	962	1394	1944	2530	3453
	Add Kg/100	3	3.2	4.4	6.6	7.3	9.4	12	15.9	18	20	28	35.7	40.5	48.3
B	L	585	640	730	830	860	1000	1120	1230	1310	1555	1740	1905	2100	2240
	Weight(kg)	54	66	85	116	148	249	329	438	557	953	1343	1745	2440	2850
C	L	340	380	440	520	540	600	680	740	820	940	1060	1160	1320	1400
	Weight(kg)	38	50	70	90	130	185	250	330	472	760	1000	1400	1480	2700
D	Lmin	430	474	544	636	690	760	860	940	1060	1180	1360	1460	1720	1790
	Weight(kg)	45	57	77	104	155	220	291	375	531	855	980	1700	2343	3240
	Add Kg/100	3	3.2	4.4	6.6	7.3	9.4	12	15.9	18	20	28	35.7	40.5	48.3
E	Lmin	715	800	880	1000	1055	1210	1345	1480	1630	1860	2122	2338	2640	2960
	Weight(kg)	59	79	95	121	189	305	395	518	693	1267	1452	2260	2820	3921
	Add Kg/100	3	3.2	4.4	6.6	7.3	9.4	12	15.9	18	20	28	35.7	40.5	48.3

Cardan Shaft Series SWC - Modified - No Face Key

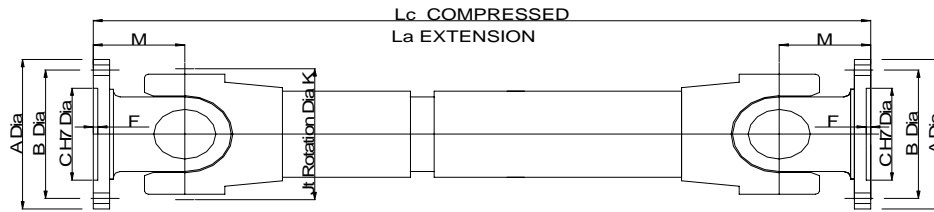

Z= No of Holes , H= Hole Dia , B= Hole PCD

Cardan Shaft Series	SWC225 MOD	SWC225-250	SWC250-285	SWC285-315	SWC315-350	SWC350-390	SWC390-435
Nominal Torque ,Mz KNm	50	50	71	100	140	200	280
Fatigue Torque Mdw KNm	25	25	35.5	50	70	100	140
Bearing Load Rating , CR KNm	11.4	11.4	19.1	26.4	36.6	50	70
A Flange Dia , mm	225	250	285	315	350	390	435
B Bolt Hole PCD mm	196	218	245	280	310	345	385
G , Flange Thickness mm	20	20	20	22	25	28	32
Z , No of Holes	8	8	8	8	10	10	10
H , Hole Dia mm , Tol C12	16	18	20	22	22	24	27
C , Spigot Dia mm , Tol H7	140	140	175	175	220	250	280
F, Spigot Depth mm	5	6	7	7	8	8	10
M , mm	120	120	140	160	180	194	215
Jt angle Max , Degrees	15	15	15	15	15	15	15
Lc , Compressed Min mm	920	920	1035	1190	1315	1410	1590
La , Extension mm	140	140	140	140	140	150	170
K , Joint Rotation Dia	225	225	250	285	315	350	390
Tube OD , mm	152	152	168	194	219	267	267
Weight - Lc min Kg	130	130	180	275	390	610	760
MR^2 - Lc min Kg.M^2	0.54	0.54	0.97	2.01	3.6	10	12
Weight Tube/100 mm	4.9	4.9	5.3	6.3	8	15	15
MR^2 Tube/100 mm Kg.M^2	0.024	0.024	0.028	0.051	0.08	0.25	0.25

Note - Special Shafts - Shorter Length or Extra Slip or Different End Flanges on request

Universal Joint Bearing Life, $B_{10} = 1.5 \cdot 10^7 \cdot (CR/Q)^{3.33} / (N \cdot B \cdot K_b)$ Hours

Q = Transmitted Torque in KNm , N= Operating Speed in RPM , B = Operating Joint angle in Degree or 2 whichever is higher

$K_b = 1.0$ for Elec Motor or Turbine Drive / 1.2 for Diesel Engine Drive

Unique Transmission (India) Pvt Ltd
 10/1D Lal Bazar Street , Kolkata 700001

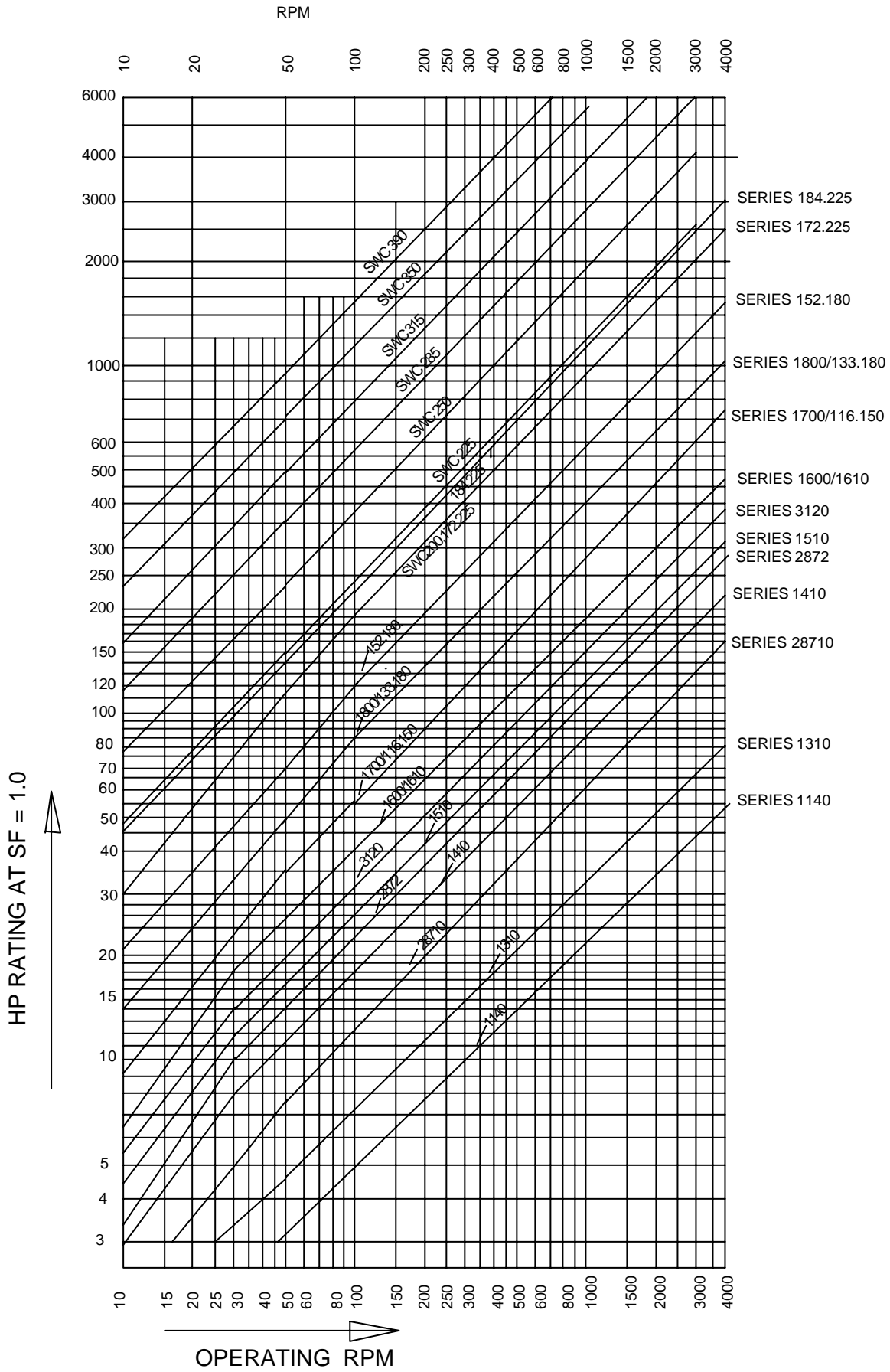

Unique Transmission (India) Pvt Ltd. Installation , Operation & Maintenance

Warning

These instruction are only general instructions for installation , operation & maintenance of cardan shaft assemblies. Unique Transmission (India) Pvt Ltd shall not be liable either directly or indirectly for any accident /injury that may occur as a result of using these shafts.

Assembly , disassembly & maintenance operations shall be done only by trained & qualified personnel Drive shafts are also parts , due to their intrinsic nature , can cause damages to persons or things during their duty even if they are correctly dimensioned and installed. Therefore user must take all necessary precautions so as to prevent and avoid such damages by intalling necessary protection guards etc.

Checking Correct Installation

In order to ensure constant velocity transfer of motion shafts should be arranged correctly either in Z arrangement or W arrangement as shown in sketch below. Driving & driven Joint angle should be equal - max difference in angle can be 1 degree. Non observance of this causes vibration & failure of shaft.

Z - arrangement driving (input) shaft & driven shaft (output) should be parallel within 1 degree.

W arrangement - ensure driving Joint angle is equal to driven Joint angle.

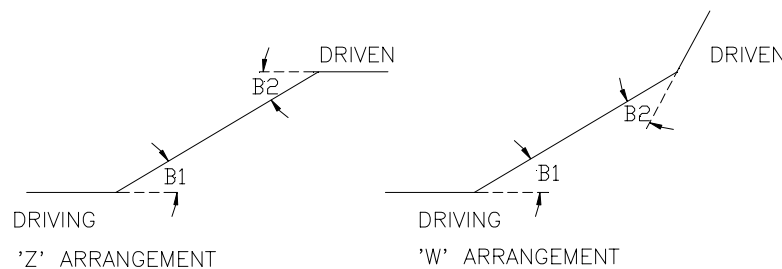

Maximum Allowable Working Speed

Please check critical speed is at least 30 % higher than operating speed well above operating speed . Consult Unique for calculation of critical speed. (Such calculation normally required required for shafts longer than 1000 mm operating at speed 750 rpm or higher.)

While selecting cardan shaft Joint angle must be considered. In any case , joint angle must not exceed following figures in degrees for smooth operation

Series	Operating RPM			
	500 rpm	1000 rpm	1500 rpm	3000 rpm
Max operting joint angle in degrees				
1140	20	20	16.6	8.3
1310	20	20	16.6	8.3
28710	18	18	15.2	7.6
2872	20	20	15.2	7.6
1410	20	20	15.2	7.6
1510	20	18	12	6
3120	20	18	12	6
1600	20	18	12	6
1700	20	18	12	6

Unique Transmission India Pvt Ltd

Installation , Operation & Maintenance

Unique Cardan Shafts Series 116.150,133.180 , 144.180 ,152.180, 185.225

Warning

These instructions are only general instructions for installation , operation & maintenance of cardan shaft assemblies. Unique Transmission (India) Pvt Ltd . shall not be liable either directly or indirectly for any accident /injury that may occur as a result of using these shafts.

Assembly , disassembly & maintenance operations shall be done only by trained & qualified personnel. Drive shafts are also parts , due to their intrinsic nature , can cause damages to persons or things during their duty even if they are correctly dimensioned and installed. Therefore user must take all necessary precautions so as to prevent and avoid such damages by installing necessary protection guards etc.

Checking Correct Installation

In order to ensure constant velocity transfer of motion shafts should be arranged correctly either in Z arrangement or W arrangement as shown in sketch below. Driving & driven Joint angle should be equal - max difference in angle can be 1 degree. Non observance of this causes vibration & failure of shaft.

Z - arrangement driving (input) shaft & driven shaft (output) should be parallel within 1 degree.

W arrangement - ensure driving Joint angle is equal to driven Joint angle.

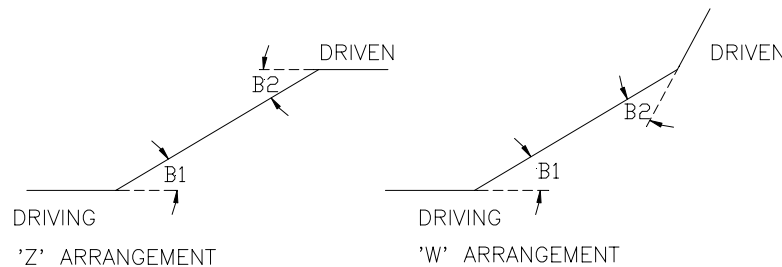

Maximum Allowable Working Speed

Please check critical speed is at least 30 % higher than operating speed well above operating speed .

Consult Unique for calculation of critical speed. (Such calculation normally required for shafts longer than 1000 mm operating at speed 750 rpm or higher.)

While selecting cardan shaft Joint angle must be considered. In any case , joint angle must not exceed following figures for smooth operation

Cardan shaft Series	116.150	133.180	144.180	152.180	185.225
Operating rpm					
	Maximum Joint Angle in degrees				
500	35	35	35	25	22
1000	20	18	18	15	15
1500	13	12	12	10	10
3000	6.7	6.5	6.5	5.2	5.2

Higher joint angles can cause vibration & noise.

Handling Drive Shafts

The wrong handling of shafts may cause serious damage to them. Drive shaft must always be handled horizontally & if it is necessary to deviate from this position, all precautions must be taken so that two sides do not separate & come out. If slings have to be used, these should be used in Yokes as shown in sketch using adequate ropes. Never use UJ cross for handling drive shaft.

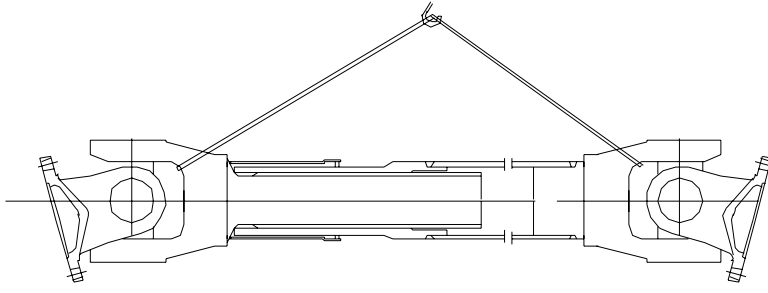

General assembly Rules

Make sure angular location of Yokes is correct. The Yokes should be in same line. Check for Arrow Marks/match marks.

Take care of cleaning the surfaces that will come in contact, most of all that concerns lubricants, rust, paint & dirt. Remove any safeties that may have been set against accidental coming out during transportation. During assembly do not force with levers or other tools specially in Universal Joint Area. Make sure that bolts are tightened by torque wrench to recommended tightening torque. In case of painting make sure area where sealing slides shall not be painted.

Disassembly -

Before disassembly necessary precaution must be taken to avoid falling or coming out of pieces. Refer to recommendation concerning handling and the assembly.

Maintenance -

Maintenance Interval will depend on environmental and working conditions. However we suggest that you carry out regularly, planning with maintenance of other components - but without extending them over six months. The controls to be made concern correct tightening of bolts & control of play in Spiders (U Joints) and of sliding action. For washing drive shafts do not use steam or pressure water. Do not use aggressive chemical detergents. In case of washing an accurate regreasing must be provided.

Lubrication

After drive shafts have been installed always check correct filling with grease of the Universal Joints. The pumping of grease should be continued until grease comes out from sealing. Lubrication of Universal Joints should be done after every 2000 Hours of running or 12 months whichever is earlier. In order to regrease always use Lithium Base Grease such as : Servo Multipurpose of IOC, Multipurpose Grease of Indrol, Multipurpose Grease MP II of Bharat Petroleum.

The sliding section (coated with anti friction material) does not need normally lubrication In case lubrication is wanted , quantity of grease must not be more than 30 grams. A check should be made once in 12 months & lurication of sliding part done if necessary.

Safety Precautions

- ***A serious fatal Injury can occur
 - if you lack proper training
 - if you fail to to use proper tools & safety equipment
 - if you use incompatible drive shaft components
 - if you use wornout damaged drive shaft components
- *** Donot work on drive shaft (with or without guard) when machine is operating
- *** Drive shafts can be dangerous . You can entangle clothes , skin , hair, hands etc .
This can be fatal or cause serious injury.

Ordering Spares -

For ordering spares - please state

Shaft Model Number (This is essential) & description of part , viz

Spares for Unique Cardan shaft Series 132.180 , Drg No

Spare UJ Cross Kit

Spare Fixed Joint (Flange Yoke + UJ Cross Kit + Stub Yoke)

Spare Slip Joint (Flange Yoke + UJ Cross Kit + Sleeve Yoke + Spline shaft)

Spare Complete shaft assembly 132.180 - Unique Drg No

Please note each UJ cross Kit comprises 1 no UJ cross & 4 no Needle cups complete with needle roller bearings.

Adequate spares should be kept & ordered well in time - Lead time (if out of stock) can be 18 to 20 weeks.

Unique Transmission India Pvt Ltd Installation , Operation & Maintenance Cardan Shafts SWC Type

Warning

These instructions are only general instructions for installation, operation & maintenance of cardan shaft assemblies. Unique Transmission (India) Pvt Ltd. shall not be liable either directly or indirectly for any accident /injury that may occur as a result of using these shafts.

Assembly, disassembly & maintenance operations shall be done only by trained & qualified personnel. Drive shafts are also parts, due to their intrinsic nature, can cause damages to persons or things during their duty even if they are correctly dimensioned and installed. Therefore user must take all necessary precautions so as to prevent and avoid such damages by installing necessary protection guards etc.

Checking Correct Installation

In order to ensure constant velocity transfer of motion shafts should be arranged correctly either in Z arrangement or W arrangement as shown in sketch below. Driving & driven joint angle should be equal - max difference in angle can be 1 degree. Non observance of this causes vibration & failure of shaft.
 Z - arrangement driving (input) shaft & driven shaft (output) should be parallel within 1 degree.
 W arrangement - ensure driving joint angle is equal to driven joint angle.

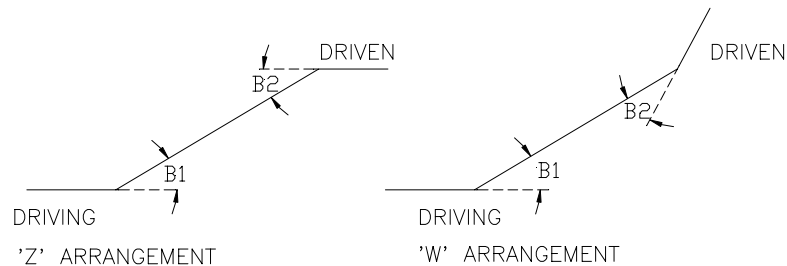

Maximum Allowable Working Speed

Please check critical speed is at least 30 % higher than operating speed well above operating speed. Consult Unique for calculation of critical speed. (Such calculation normally required for shafts longer than 1000 mm operating at speed 750 rpm or higher.)

While selecting cardan shaft joint angle must be considered. In any case, joint angle must not exceed following figures for smooth operation

Cardan shaft Series	SWC 225	SWC 285	SWC 350	SWC 440
	250	315	390	
Operating rpm	Maximum Joint Angle in degrees			
300	15	15	15	15
500	15	15	15	12
1000	12	11	8.5	6
1500	9	7	5.5	4

Handling Drive Shafts

The wrong handling of shafts may cause serious damage to them. Drive shaft must always be handled horizontally & if it is necessary to deviate from this position, all precautions must be taken so that two sides do not separate & come out. If slings have to be used, these should be used in Yokes as shown in sketch using adequate ropes. Never use UJ cross for handling drive shaft.

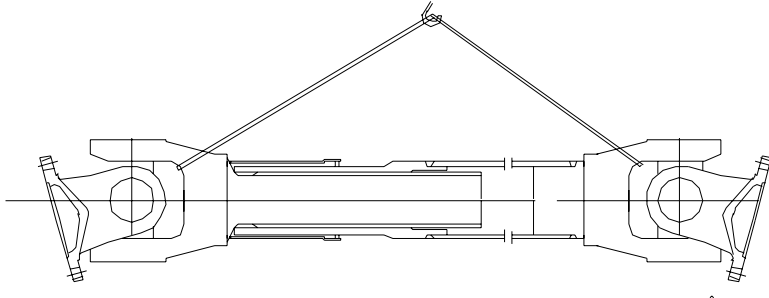

General assembly Rules

Make sure angular location of Yokes is correct. The Yokes should be in same line. Take care of cleaning the surfaces that will come in contact, most of all that concerns lubricants, rust, paint & dirt. Remove any safeties that may have been set against accidental coming out during transportation. During assembly do not force with levers or other tools specially in Universal Joint Area. Make sure that bolts are tightened by torque wrench to recommended tightening torque.

Disassembly -

Before disassembly necessary precaution must be taken to avoid falling or coming out of pieces. Refer to recommendation concerning handling and the assembly.

Disassembly & replacement of UJ Cross Kits

Tap one end of the bearing lightly to remove pressure on snap ring. Remove snap ring with pliers; Repeat procedure for opposite bearing. Then drive with a soft drift on one bearing to push the opposite bearing through its yoke. Remove exposed bearing, turn the joint over and remove the first bearing by driving on the exposed end of the journal cross. Repeat the process for the other two bearings.

Reassembly

Remove the bearings from new cross assembly, holding the cups so that needles do not fall out. Position the cross in one Yoke. Position one bearing cup with its needles in the Yoke and insert the journal of the cross into the bearing. Press bearing into the Yoke. Repeat for the opposite bearing. If press is not available use a vice. Never hammer on new bearings. Install snap ring and repeat operation for next two bearings.

Maintenance -

Maintenance Interval will depend on environmental and working conditions. However we suggest that you carry out regularly, planning with maintenance of other components - but without extending them over six months. The controls to be made concern correct tightening of bolts & control of play in

Spiders (U Joints) and of sliding action. For washing drive shafts donot use steam or pressure water. Donot use aggressive chemical detergents. In case of washing an accurate regreasing must be provided

Lubrication

After drive shafts have been installed always check correct filling with grease of the Universal Joints. The pumping of grease should be continued until grease comes out from sealing. Lubrication of Universal Joints should be done after every 3 months .Sliding Splines should also be similarly lubricated every 3 months.

In order to regrease always use Lithium Base Grease such as :
Servo Multipurpose of IOC , Multipurpose Grease of Indrol , Multipurpose Grease MP II of Bharat Petroleum.

Safety Precautions

Rotating parts are potentially dangerous and must be properly guarded.

Use proper tools & safety equipment

Do not use incompatible drive shaft components

Do not use worn out damaged drive shaft components

*** Donot work on drive shaft (with or without guard) when machine is operating

*** Drive shafts can be dangerous . You can entangle clothes , skin , hair, hands etc .

This can be fatal or cause serious injury.